

VENTILATORI CENTRIFUGHI

SERIE: PL - PM - PA

Serie: PL

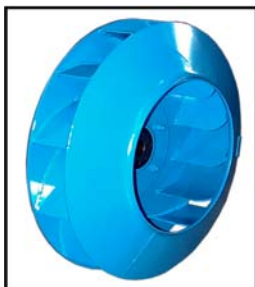

Ventilatori previsti per portate fino a 60 m³/s e pressioni totali fino a 450 mm H₂O. Girante a pale curve rovesce di spessore costante adatta per il trasporto di aria, fumi caldi e leggermente polverosi. Per l'elevato rendimento della girante se ne consiglia l'impiego in tutti i casi in cui le condizioni del fluido trasportato lo permettano.

A 40

Serie: PM

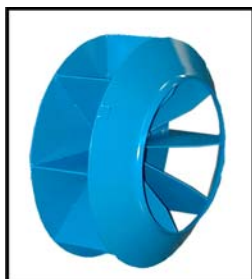

Ventilatori con girante a pale radiali adatta per il trasporto di aria, fumi caldi e molto polverosi, materiali granulosi e polveri anche abrasive. La curva della potenza cresce verso la bocca libera ed è quindi buona norma scegliere il motore con un 25% di margine di potenza per poter sopperire ad eventuali perdite di circuito non preventivate.

A 41

Serie: PA

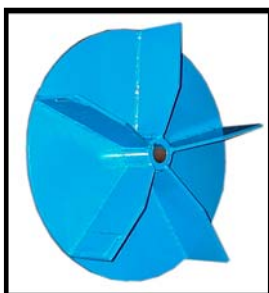

Ventilatori con girante a pale radiali, aperta, provvista cioè del solo disco posteriore. L'assenza del disco anteriore permette il passaggio di materiali che di solito tendono ad intasare le giranti normali: trucioli di legno, ritagli di carta e materiali filacciosi in genere. Anche in questo caso è opportuno scegliere un motore con un margine di potenza del 25% rispetto alle perdite di circuito calcolate.

A 42

VENTILATORI SERIE: PL / PM / PA - SCHEMA DIMENSIONALE

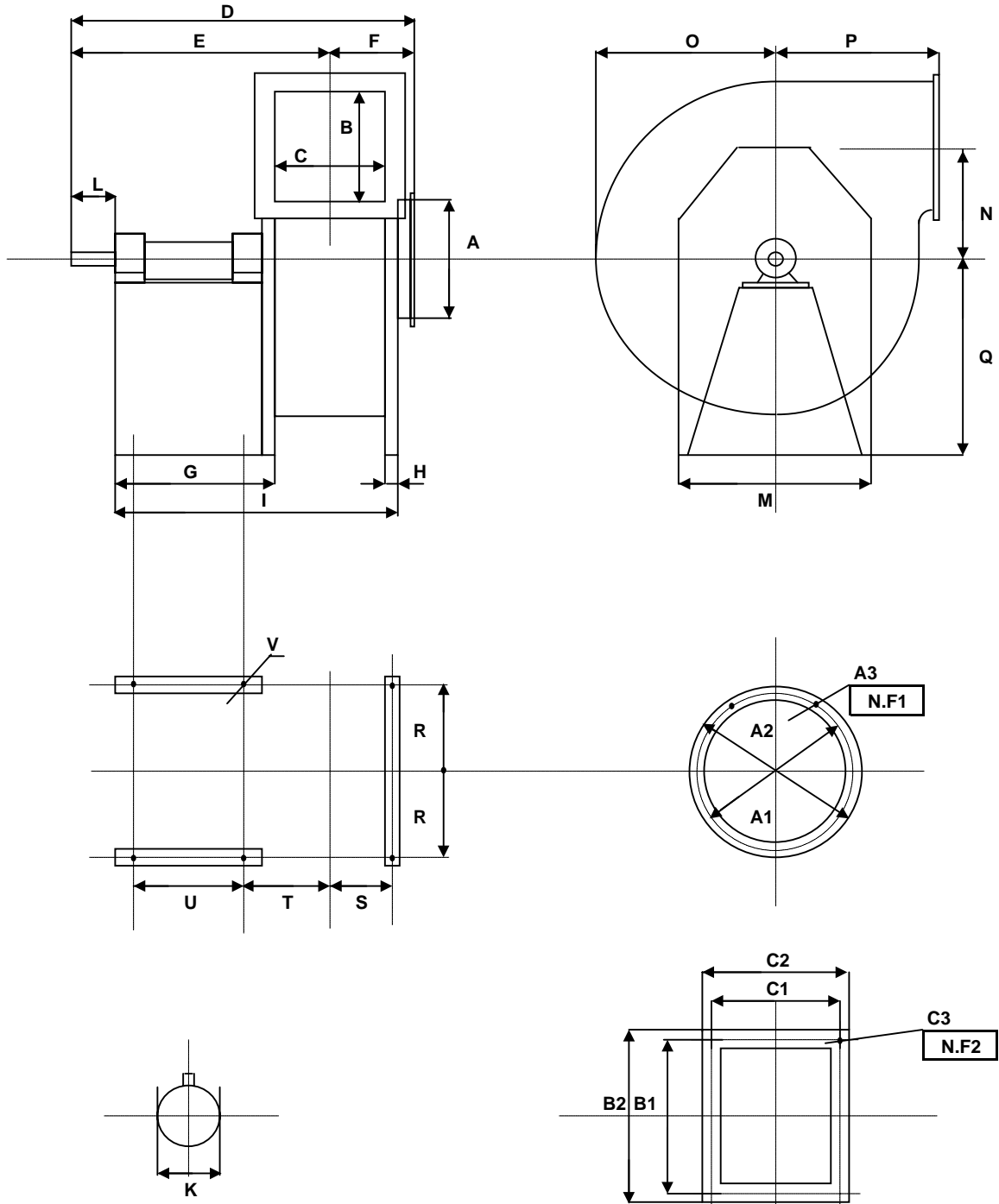

VENTILATORI SERIE: PL / PM / PA - TABELLA DIMENSIONALE

SERIE	GRANDEZZA											
PL-PM-PA	410	450	500	550	610	670	740	820	900	1000	1100	1200
A	300	315	350	400	450	500	550	600	650	700	750	850
B	250	275	300	348	375	415	460	500	554	610	670	750
C	220	246	272	305	336	370	405	446	495	540	600	660
D	812	838	1021	1058	1088	1215	1270	1310	1400	1448	1698	1758
E	620	633	816	833	848	958	975	995	1060	1083	1293	1323
F	182	195	205	225	240	257	295	315	340	365	405	435
G	430	430	600	600	600	660	660	660	670	670	850	850
H	40	40	50	50	50	55	55	55	55	55	100	100
I	690	716	922	955	986	1085	1120	1161	1220	1265	1550	1610
L	80	80	80	80	80	110	110	110	140	140	140	140
M	575	575	775	775	775	940	940	1150	1150	1150	1360	1500
N	281	320	336	381	420	467	508	572	620	695	769	847
O	370	415	444	497	547	604	660	734	801	890	974	1075
P*	336	336	440	440	440	530	530	635	635	700	835	905
P* 180°/225°	600	630	705	755	815	875	950	1050	1130	1230	835	905
Q* 90°/135°	465	500	560	610	670	730	800	880	960	1060	880	970
Q* 0°/45°	465	500	560	610	670	730	800	880	960	1060	1045	1160
Q* 180°/225°	465	500	560	610	670	730	800	880	960	1060	638	708
Q* 270°/315°	465	500	560	610	670	730	800	880	960	1060	1165	1280
R	270	270	365	365	365	445	445	550	550	550	660	730
S	137	148	168	182	198	216	236	256	282	306	352	385
T	140	153	166	183	198	220	238	258	283	305	340	370
U	370	370	540	540	540	590	590	590	600	600	770	770
V	11	11	11	11	13	13	13	13	13	13	13	13
K	38	38	38	38	38	48	48	48	60	60	65	65
A1	332	344	382	432	482	532	585	635	700	750	800	900
A2	360	374	410	460	510	560	617	662	737	787	837	937
A3	9	9	9	9	9	9	9	9	12	12	12	12
N. F1	6	6	8	8	10	10	12	14	12	12	12	12
B1	286	310	334	382	410	450	494	534	590	660	720	800
B2	314	337	362	410	437	477	522	562	638	696	756	836
C1	256	280	306	340	370	404	440	480	540	590	650	710
C2	284	308	334	367	398	432	467	508	579	626	686	746
C3	11	11	11	11	11	11	11	11	11	12	12	12
N. F2	8	8	8	8	8	8	12	12	12	12	12	12

Tabella non impegnativa

- * Quota variabile, per le grandezze da 450 a 1000, solo nelle configurazioni RD/LG 180° - 225°.
- Quota variabile, per le grandezze 1100 e 1200, nelle varie configurazioni RD/LG da 0° a 315°.

Serie: PA

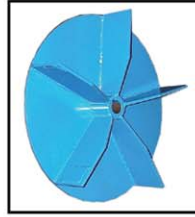

PA 410 **Girante ϕ 411**
Bocca aspirante ϕ 300 - Bocca premente 220 x 250

PA 450 **Girante ϕ 459**
Bocca aspirante ϕ 315 - Bocca premente 246 x 275

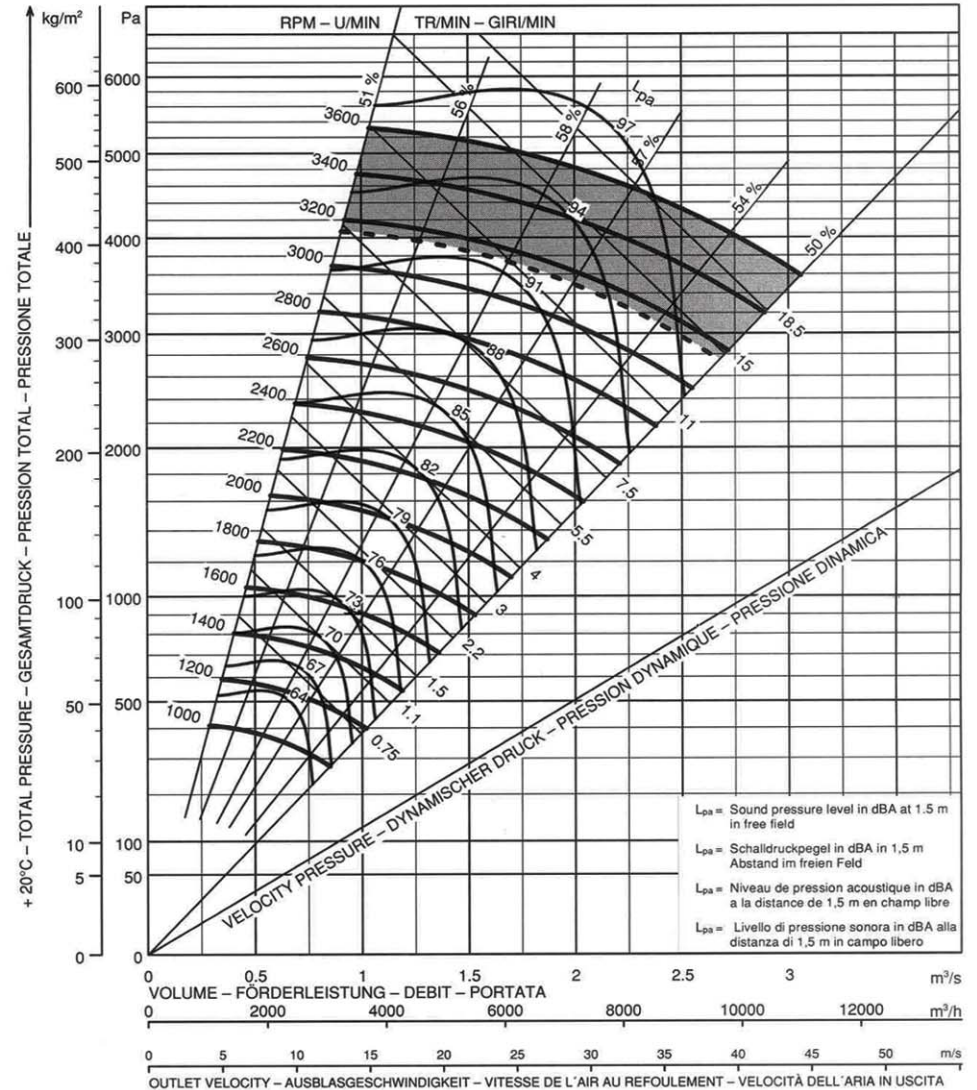
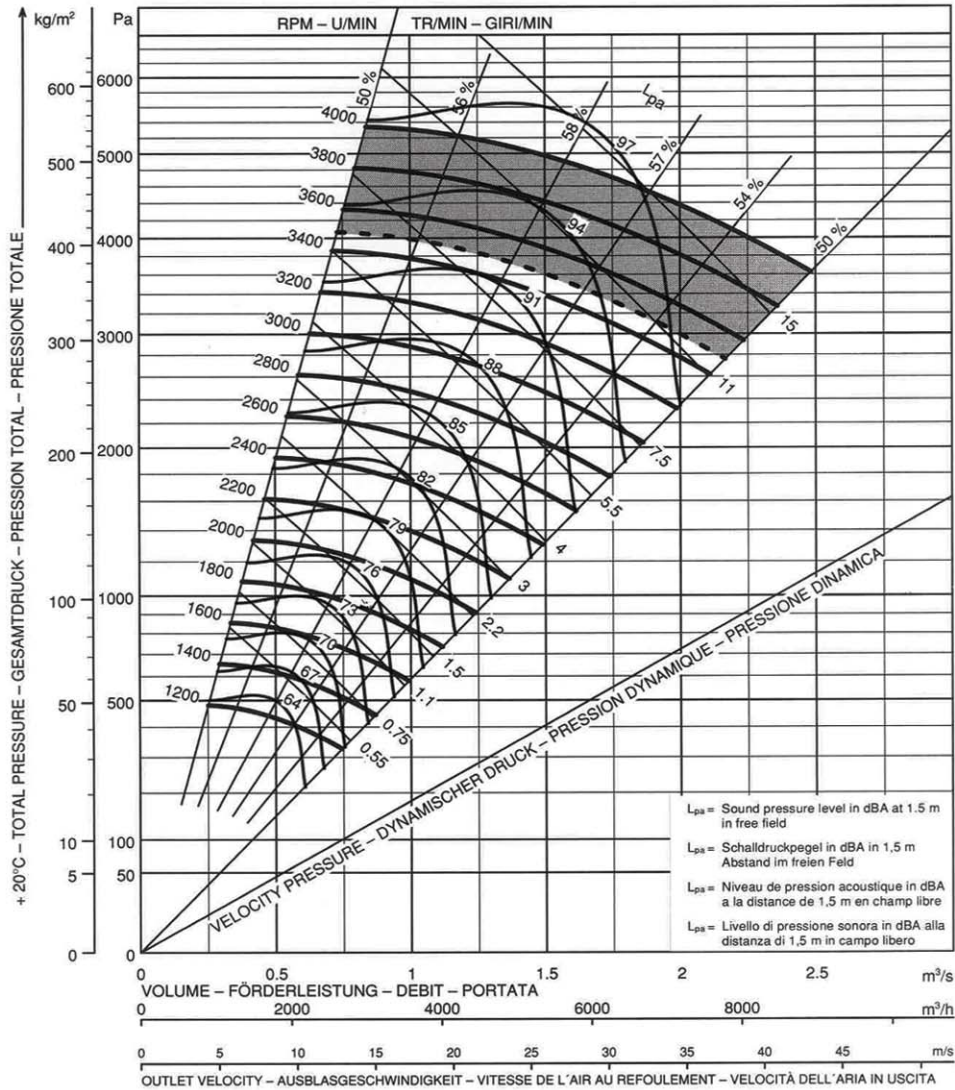

Serie: PA

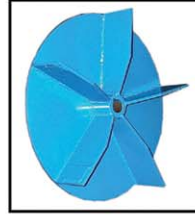

PA 500 **Girante ϕ 500**
Bocca aspirante ϕ 350 - Bocca premente 272 x 300

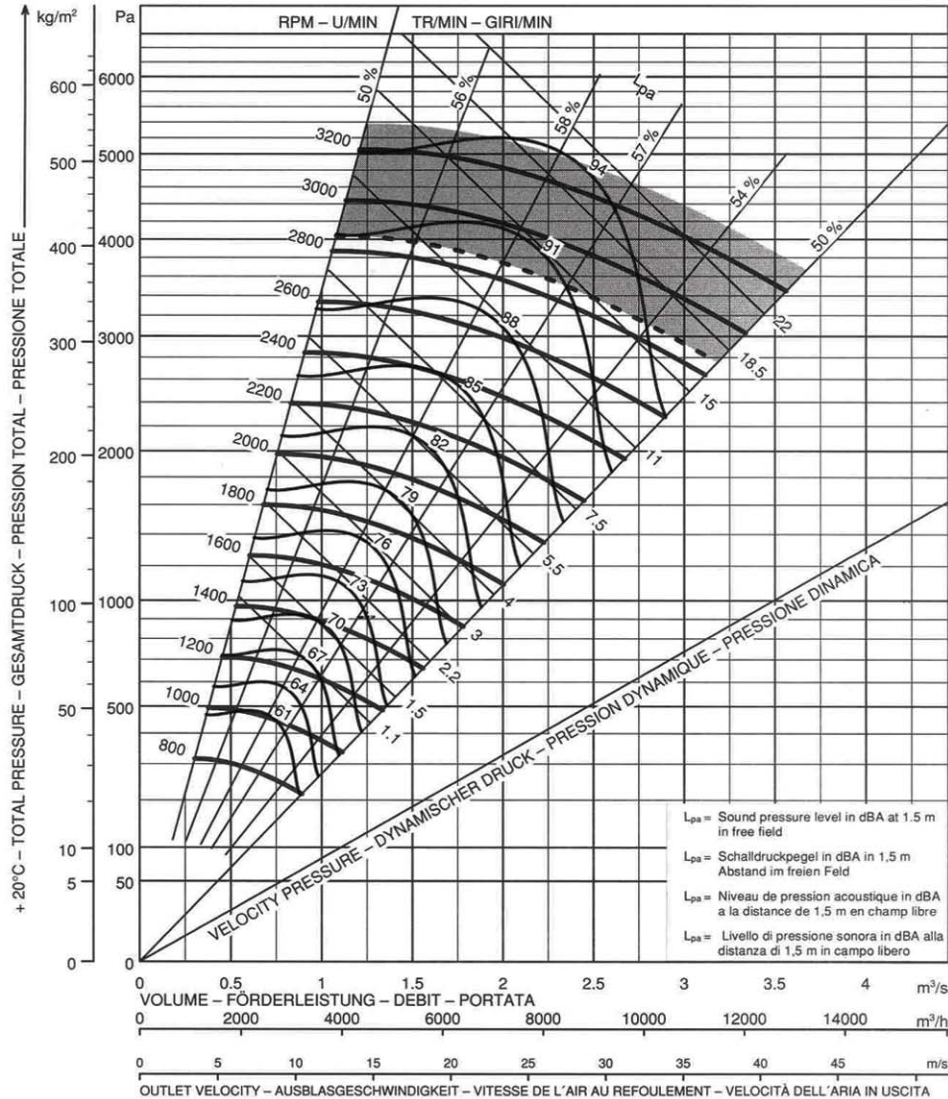

PA 550 **Girante ϕ 548**
Bocca aspirante ϕ 400 - Bocca premente 305 x 348

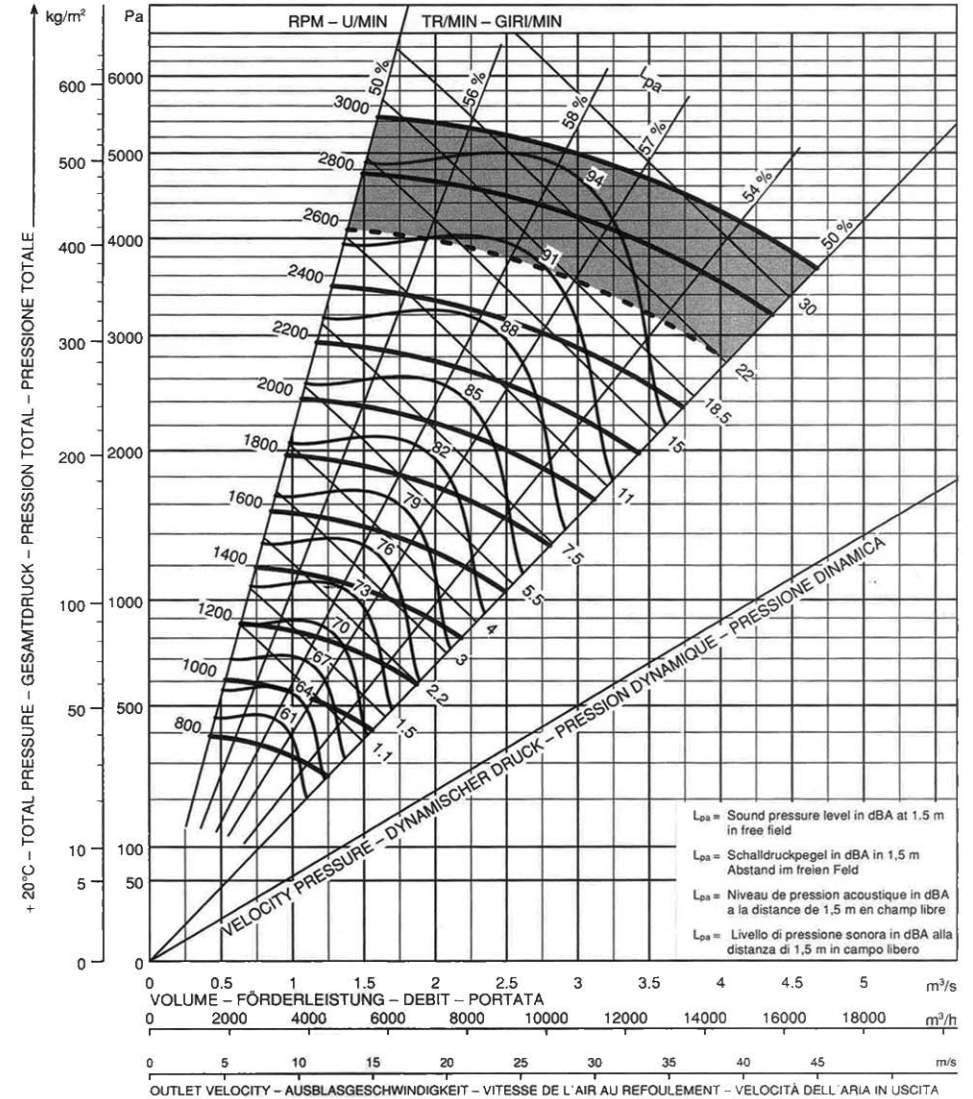

Serie: PA

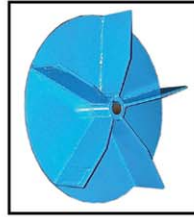

PA 610 **Girante ϕ 609**
Bocca aspirante ϕ 450 - Bocca premente 336 x 375

PA 670 **Girante ϕ 671**
Bocca aspirante ϕ 500 - Bocca premente 370 x 415

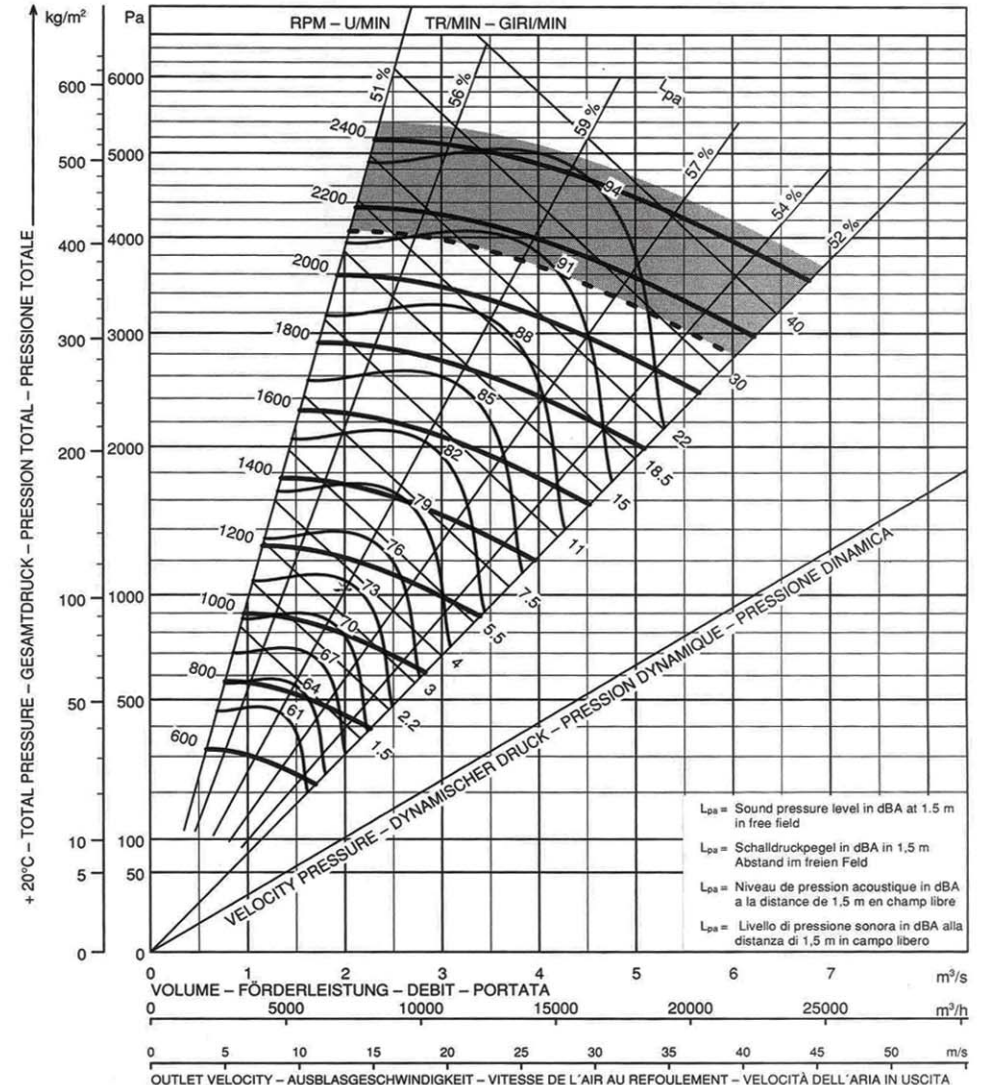
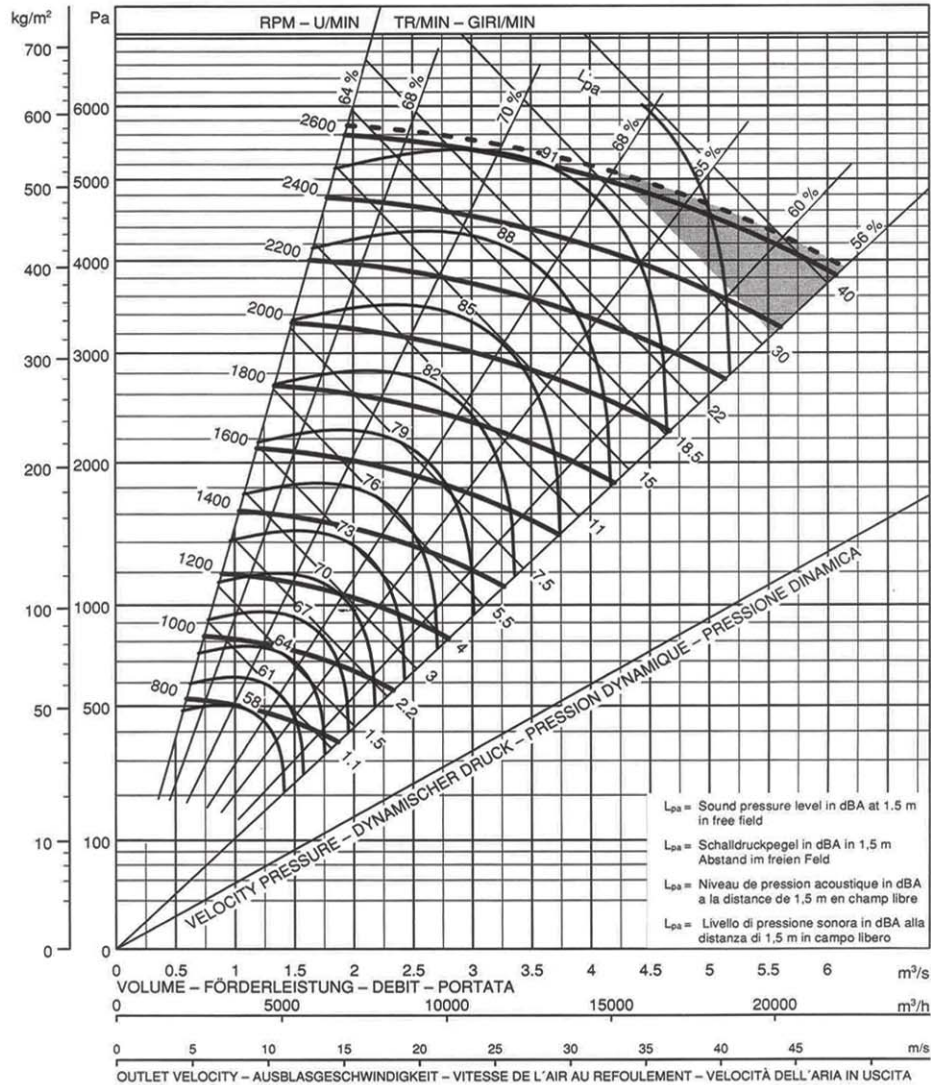

Serie: PA

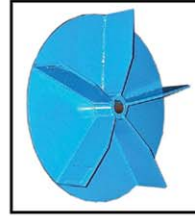

PA 740 **Girante ϕ 740**
Bocca aspirante ϕ 550 - Bocca premente 405 x 460

PA 820 **Girante ϕ 829**
Bocca aspirante ϕ 600 - Bocca premente 446 x 500

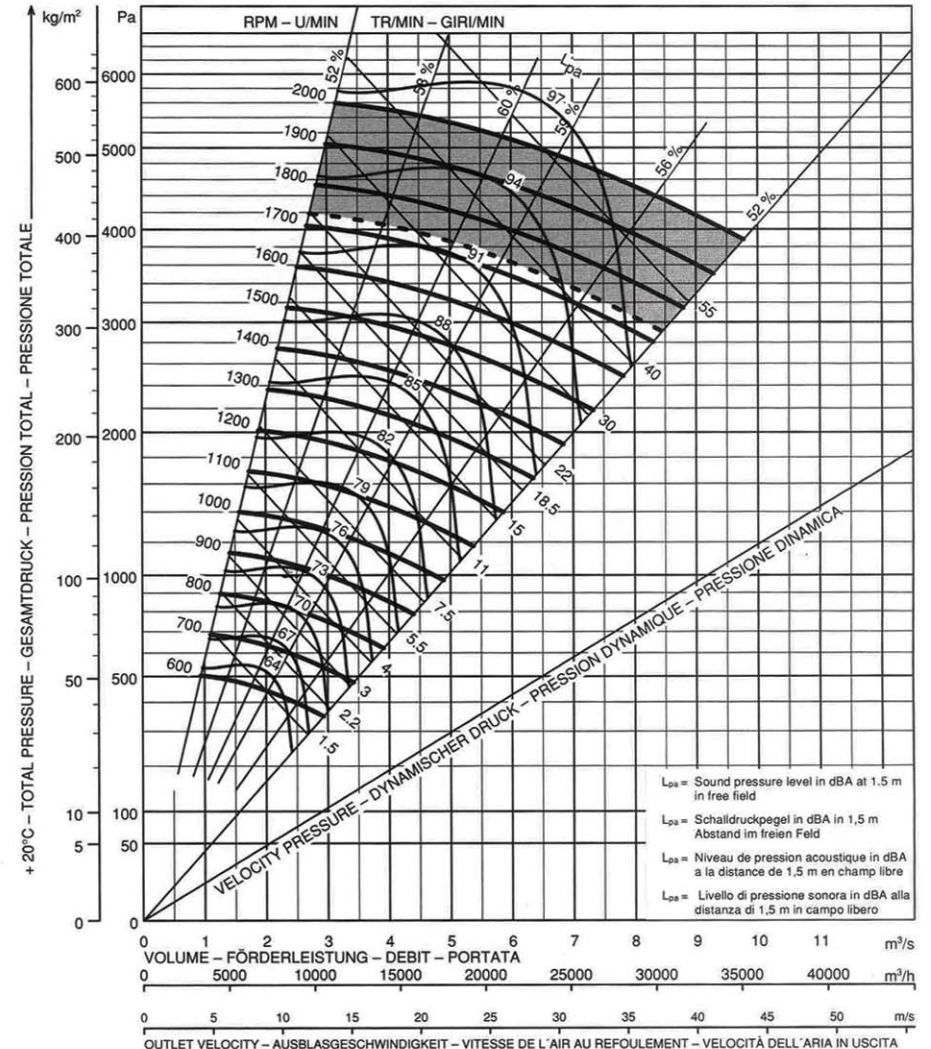
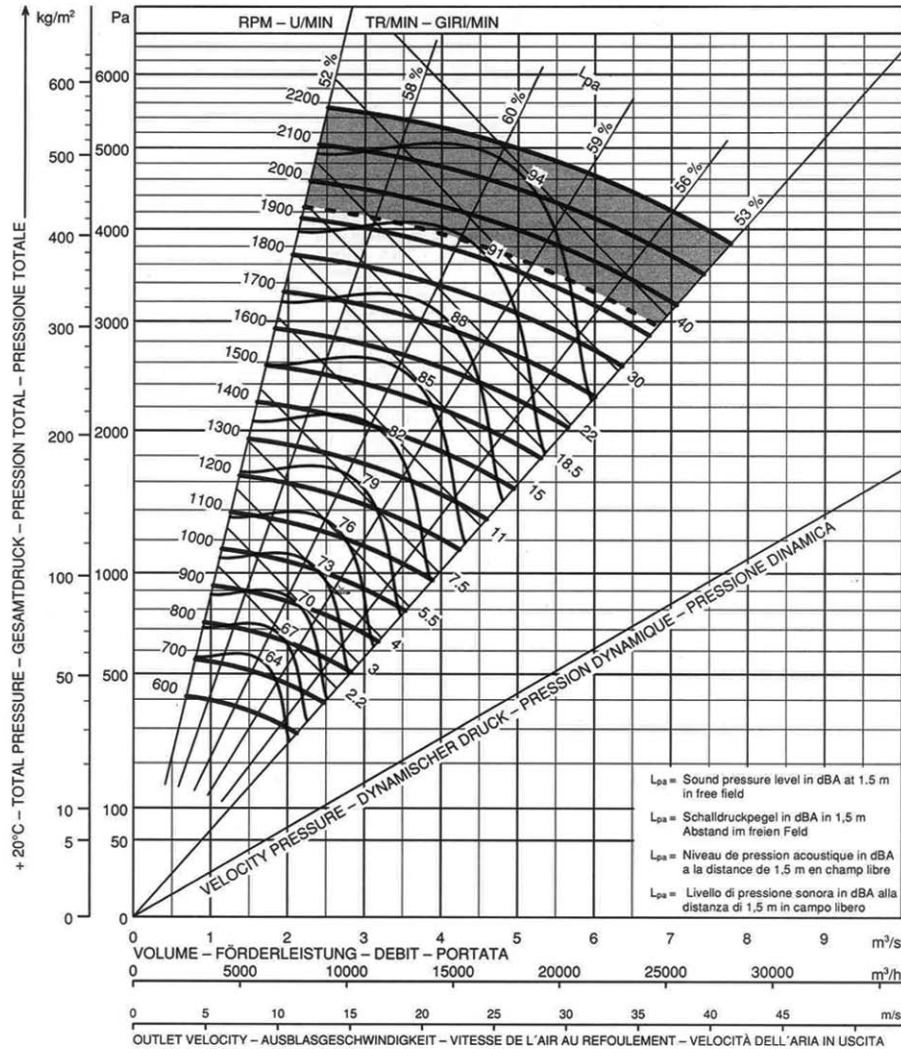

Serie: PA

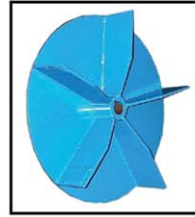

PA 900 **Girante ϕ 910**
Bocca aspirante ϕ 650 - Bocca premente 495 x 554

PA 1000 **Girante ϕ 1000**
Bocca aspirante ϕ 700 - Bocca premente 540 x 610

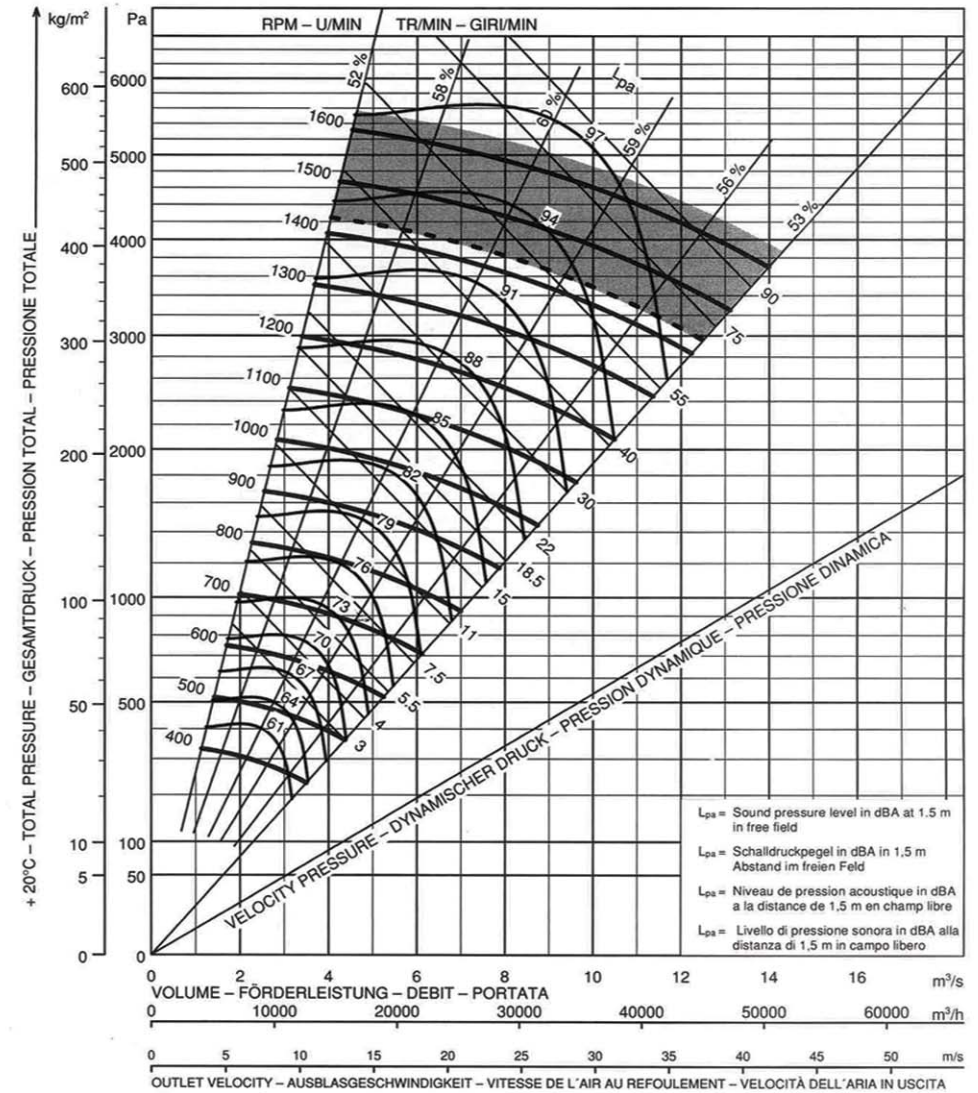
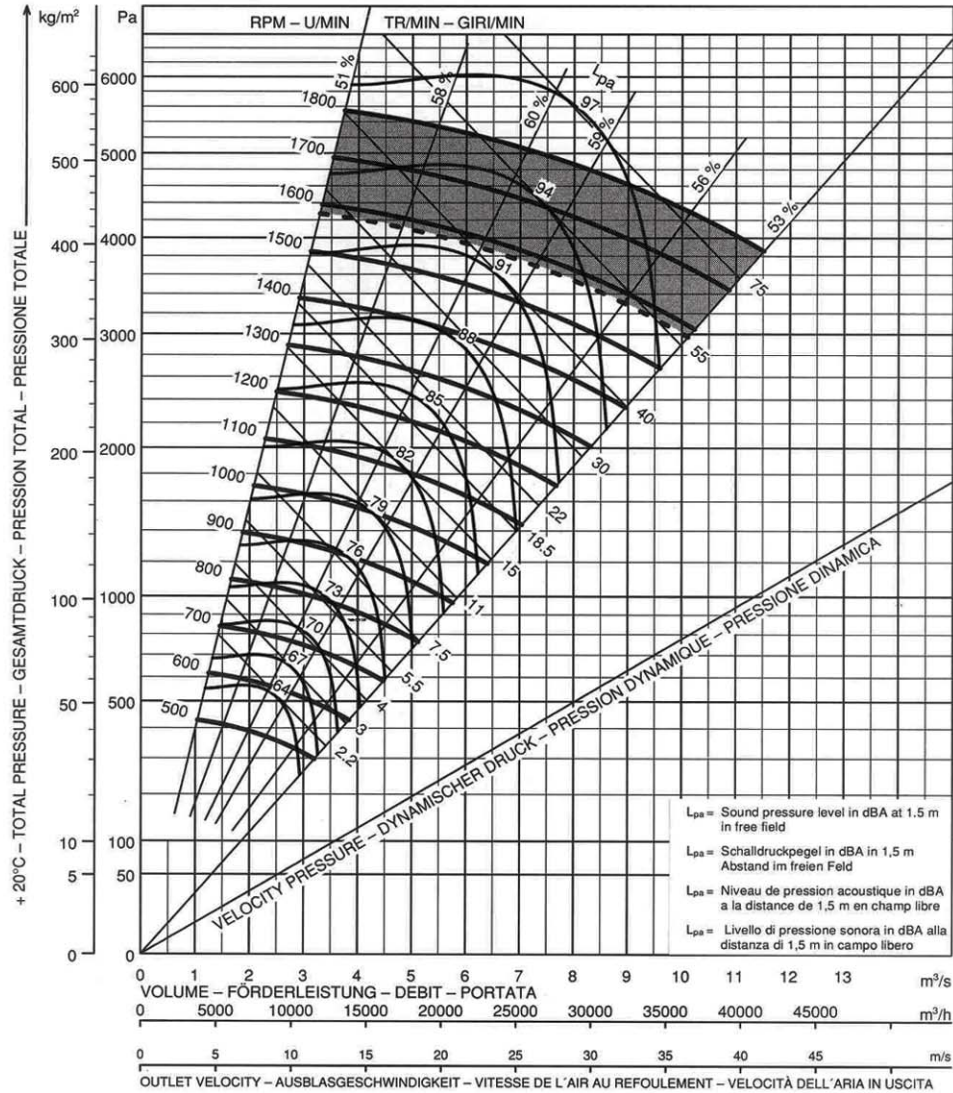

Serie: PA

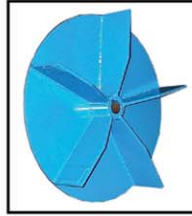

PA 1100 **Girante ϕ 1096**
Bocca aspirante ϕ 750 - Bocca premente 600 x 670

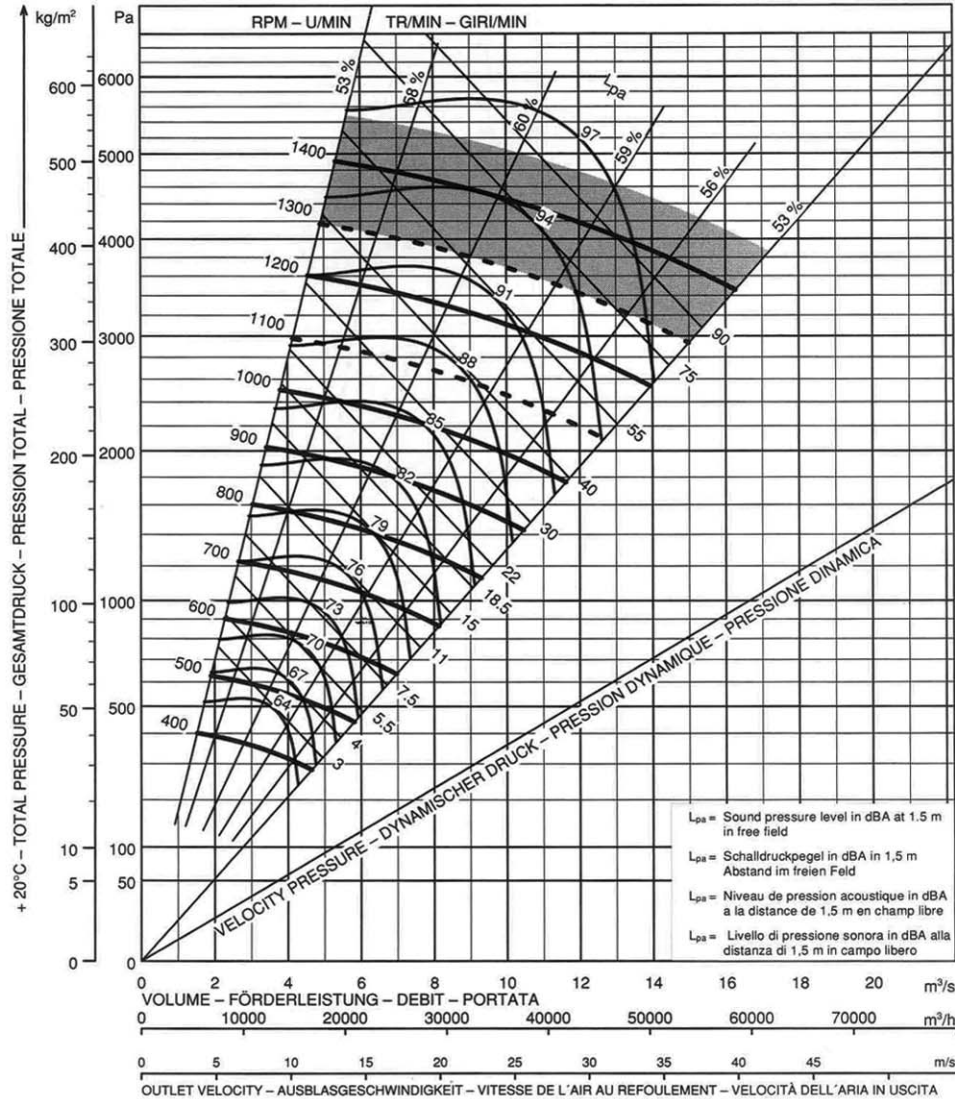

PA 1200 **Girante ϕ 1219**
Bocca aspirante ϕ 850 - Bocca premente 660 x 750

